

- 12 Pull back engine clip and slide engine into rocket as shown. When engine is fully inserted, release clip to secure engine.

- 1 Remove Safety Key.
  - 2 Remove safety cap and place rocket on launch pad.
  - 3 Attach micro clips, making sure they don't touch each other or blast deflector.
  - 4 Step back 15 feet (5 meters)
  - 5 Insert safety key, make sure everyone is aware of the launch and give an audible countdown.
- 5---4---3---2---1 LAUNCH  
PRESS BUTTON UNTIL ROCKET  
IGNITES.

#### MISFIRES

A misfire occurs if after 15 seconds, the rocket does not liftoff. The most typical cause of misfire is igniter. Wait at least a full minute before approaching a rocket after a misfire. Remove rocket, take out engine and reinstall another igniter. Make sure igniter is installed correctly and repeat launch procedure.

**DO NOT ALLOW MICRO-CLIPS TO TOUCH EACH OTHER OR BLAST DEFLECTOR!**

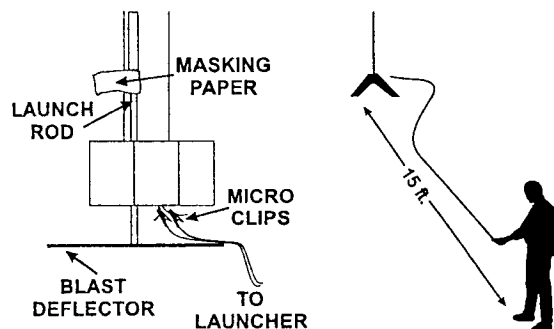

- 13 Slide launch lug over launch rod. Make sure safety key is out of launcher, and hook up microclips to igniter. Don't let microclips touch themselves, launch rod, or engine clip. Stand back at least 15 feet, and look around to make sure that everyone is aware of launch. Insert safety key and hold button for 3-4 seconds. If rocket does not take off after 15 seconds, you either have a misfire or low batteries. Remove safety key and wait another 15 seconds. Walk over, remove rocket, and try another igniter. Repeat launch procedure again.



www.customrocketcompany.com

Custom Rocket Company • P.O. Box 1865 • Lake Havasu City, AZ 86405



## Model Rocketeer's Safety Code

For more information contact [www.nar.org](http://www.nar.org)

**Materials.** I will use only lightweight, non-metal parts for the nose, body, and fins of my rocket.

**Motors.** I will use only certified, commercially-made model rocket motors, and will not tamper with these motors or use them for any purposes except those recommended by the manufacturer.

**Ignition System.** I will launch my rockets with an electrical launch system and electrical motor igniters. My launch system will have a safety interlock in series with the launch switch, and will use a launch switch that returns to the "off" position when released.

**Misfires.** If my rocket does not launch when I press the button of my electrical launch system, I will remove the launcher's safety interlock or disconnect its battery, and will wait 60 seconds after the last launch attempt before allowing anyone to approach the rocket.

**Launch Safety.** I will use a countdown before launch, and will ensure that everyone is paying attention and is a safe distance of at least 15 feet away when I launch rockets with D motors or smaller, and 30 feet when I launch larger rockets. If I am uncertain about the safety or stability of an untested rocket, I will check the stability before flight and will fly it only after warning spectators and clearing them away to a safe distance.

**Launcher.** I will launch my rocket from a launch rod, tower, or rail that is pointed to within 30 degrees of the vertical to ensure that the rocket flies nearly straight up, and I will use a blast deflector to prevent the motor's exhaust from hitting the ground. To prevent accidental eye injury, I will place launchers so that the end of the launch rod is above eye level or will cap the end of the rod when it is not in use.

**Size.** My model rocket will not weigh more than 1,500 grams (53 ounces) at liftoff and will not contain more than 125 grams (4.4 ounces) of propellant or 320 N-sec (71.9 pound-seconds) of total impulse. If my model rocket weighs more than one pound (453 grams) at liftoff or has more than four ounces (113 grams) of propellant, I will check and comply with Federal Aviation Administration regulations before flying.

**Flight Safety.** I will not launch my rocket at targets, into clouds, or near airplanes, and will not put any flammable or explosive payload in my rocket.

**Launch Site.** I will launch my rocket outdoors, in an open area at least as large as shown in the accompanying table, and in safe weather conditions with wind speeds no greater than 20 miles per hour. I will ensure that there is no dry grass close to the launch pad, and that the launch site does not present risk of grass fires.

**Recovery System.** I will use a recovery system such as a streamer or parachute in my rocket so that it returns safely and undamaged and can be flown again, and I will use only flame-resistant or fireproof recovery system wadding in my rocket.

**Recovery Safety.** I will not attempt to recover my rocket from power lines, tall trees, or other dangerous places.

Installed Total Impulse (N-sec)	Equivalent Motor Type	Minimum Site Dimensions (ft.)
0.00-1.25	1/4A, 1/2A	50
1.26-2.50	A	100
2.51-5.00	B	200
5.01-10.00	C	400
10.01-20.00	D	500
20.01-40.00	E	1000
40.01-80.00	F	1000
80.01-160.00	G	1000
160.01-320.00	Two G's	1500

# RAZOR™ INSTRUCTIONS



This kit requires white glue, scissors, and a hobby knife or razor blade. Engines, launch pad, and launch controller, are not included in this kit and must be purchased separately.

© 2006 Custom Rocket Company  
REV. 6

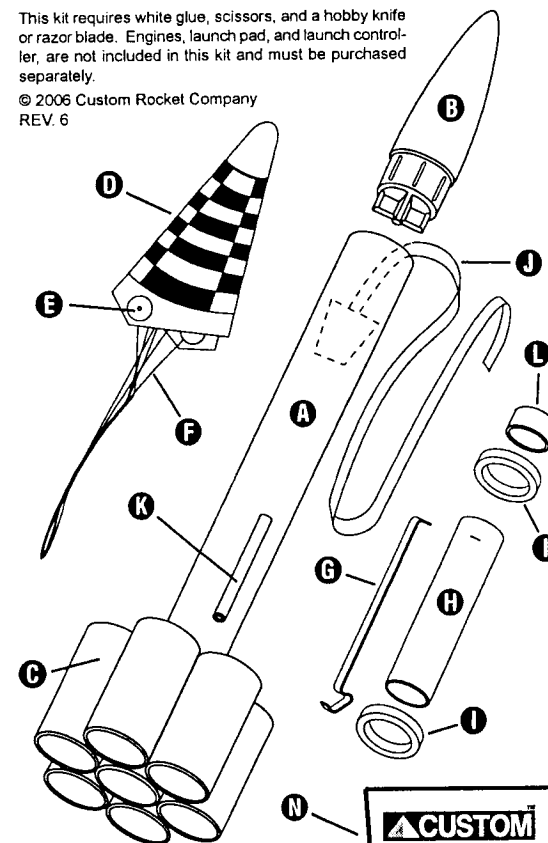

Recommended Engines: 1/2A6-2, A8-3, B4-4, B6-4, C6-5, C6-7

- A BT-509 YELLOW BODY TUBE
- B PC-50 NOSE CONE
- C TUBE FIN (6)
- D 12" PARACHUTE
- E TD-6 TAPE DISK
- F SL-72 SHROUD LINES
- G EC-2 ENGINE CLIP
- H ET-20 2.75 ENGINE TUBE W/SLIT
- I CR-2050 CENTERING RINGS
- J SC-2 SHOCK CORD
- K LUG125 YELLOW LAUNCH LUG
- L EB-20 ENGINE BLOCK
- M DECAL (NOT SHOWN)
- N SHOCK CORD MOUNT

**KIT 1001?**



www.customrocketcompany.com

Custom Rocket Company • P.O. Box 1865 • Lake Havasu City, AZ 86405

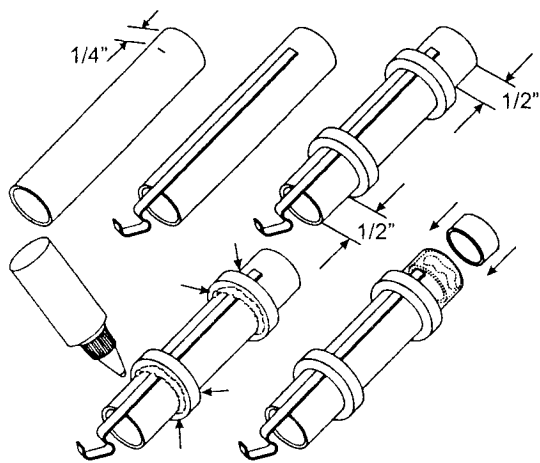

**1** Locate 1/8" slit on end of engine tube (Part H). Insert engine clip into slit. Measure and mark 1/2" from each end of engine tube with a pencil. Slide the rings onto engine tube until they are flush with marks as shown. Hold one of the rings and apply a small drop of glue to joint. While still holding ring, spread glue with your index finger around joint. The glue should fill joint and be smooth so it will dry quickly. Quickly wipe away any glue that gets on surface of ring. Apply glue to inside of engine tube, insert engine block until flush with end of tube.

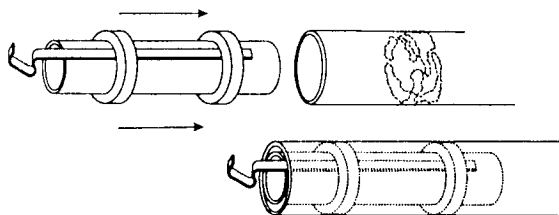

**2** The glue on joints of rings should be completely dry before starting this step. Apply white glue to inside of body tube (Part A). Glue should be about one inch inside end of tube. Insert engine mount into body tube with one swift and even motion. **DON'T STOP UNTIL BOTH TUBES ARE EVEN!**

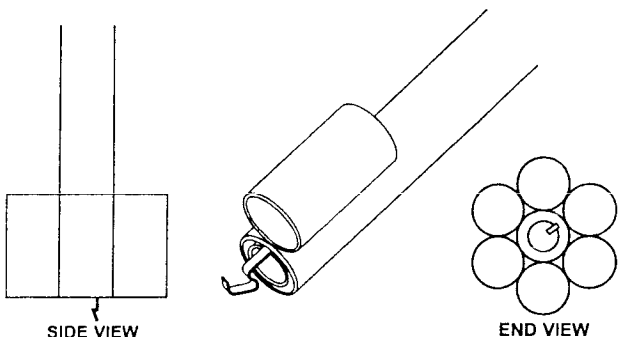

**3** Apply white glue to one of tube fins. Glue should run length of tube fin. Glue tube fin to end of body tube that has engine mount installed. Both tubes should be even. Continue gluing tube fins until all 6 tube fins have been glued.

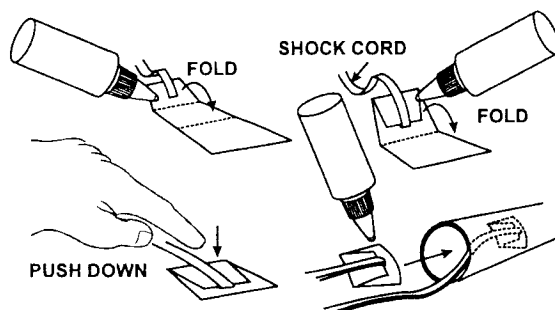

**4** Cut shock cord mount (Part N) from front of instruction sheet. Locate shock cord (Part J). Apply a drop of glue to number one and put end of shock cord into glue. Fold number one into number two, then apply glue to back of number one. Fold number two into number three. Squeeze the mount between your fingers until glue starts to set. When mount is dry, apply two drops glue to side that has Custom logo. Insert mount at least 1.5" into end of body tube.

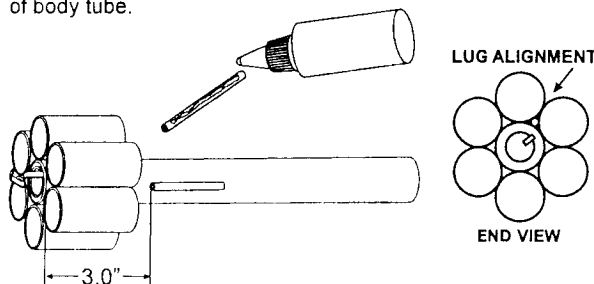

**5** Measure 3" from end of rocket. Make a mark with pencil so that it is between tubes as shown above. Apply a drop of white glue to launch lug and spread it out with your index finger. Glue launch lug to body tube at 3" mark. Lug needs to line up with joint between tubes.

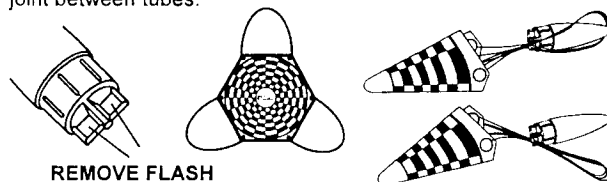

**6** Cut out the parachute with scissors. Assemble parachute using instructions provided with parachute. With a pencil or pen, clear away flash from both eyelets on nose cone. Pass shroud lines through one of eyelets on nose cone. Slide nose cone through loop in shroud line and pull tight.

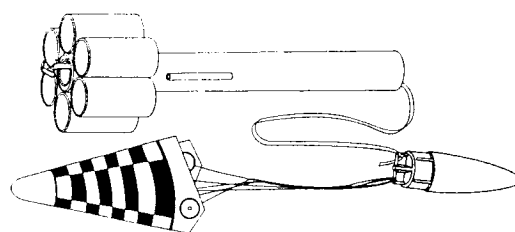

**7** Tie end of shock cord to other eyelet on nose cone.



**8** Cut pressure sensitive decal with scissors and then apply by peeling backing away. Apply to rocket as shown above.

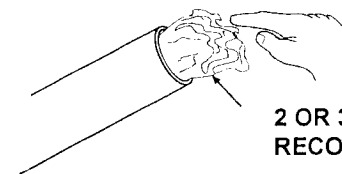

**9** To protect parachute from hot exhaust which can melt the plastic, recovery wadding must be used. loosely insert 2 or 3 squares into body tube. Fold parachute as in step 10, and then insert parachute. Place nose cone back into tube. Your rocket is now ready to launch.

**10** ALL PARTS EXCEPT PARACHUTE OMITTED FROM DRAWING TO SHOW FOLDING

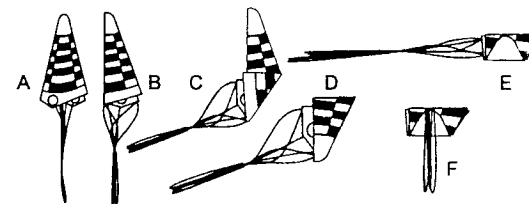

A - Pull parachute to form a spike. D - Fold top part to bottom.  
B - Fold parachute in half. E - Roll parachute.  
C - Fold bottom half over. F - Wrap shroud lines around chute.

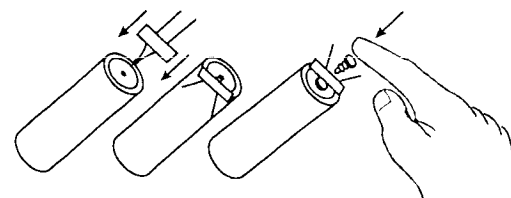

**11** Select a A8-3 engine for your first launch. This will give you an approximate altitude of 300 to 400 feet (152 - 213 m). Carefully insert igniter into engine and bend igniter. Use an erigine plug or masking tape to secure igniter in place.